



LUZERNE  
CONSERVATION DISTRICT

# Erosion and Sediment Pollution Control Plan Guide for Small Projects in Luzerne County



June 2007  
Revised April 2011

325 Smiths Pond Road  
Shavertown, PA 18708  
570-674-7991  
570-674-7989 (fax)  
[www.luzernecd.org](http://www.luzernecd.org)

## Introduction

All earth disturbance activities in the Commonwealth of Pennsylvania are regulated by the requirements of the erosion and sediment pollution control regulations found in Title 25, Chapter 102 of the Pennsylvania Code. All earth disturbance activities, including those that disturb less than 5,000 square feet, must implement and maintain Best Management Practices (BMPs) to control erosion and sediment pollution.

A written Erosion and Sediment Pollution Control (E&SPC) Plan is required if one or more of the following apply: the total area of disturbance is 5,000 square feet or greater, or if the activity has the potential to discharge to a water classified as a High Quality (HQ) or Exceptional Value (EV) water published in Chapter 93 regulations (relating to water quality standards).

This document was designed to assist in the development of an E&SPC Plan where the total area of earth disturbance is 5,000 square feet or greater and less than 43,560 square feet (one acre) on slopes that are less than 10%. Soils in the Luzerne County Soil Survey that meet the slope guidelines have a three-letter abbreviation that ends in either an **A** or **B**. (example: A1B)

Since some municipalities have local ordinances that require a written and approved E&SPC Plan even if the disturbance is less than 5,000 square feet, it is recommended you contact your local municipality to determine whether a written plan is required under a local ordinance.

Other agencies, such as the Pennsylvania Department of Environmental Protection (DEP), may require an E&SPC Plan be submitted to the conservation district office for review prior to construction. Please be aware that other federal, state and local approvals may be required, also. Contact DEP and the local municipality in which the construction is to take place to check on their requirements.

With this plan, homeowners and their earthmoving contractors should be able to develop an effective E&SPC plan for the grading of their lot. This plan, along with guidance by the conservation district office, will satisfy the Chapter 102 E&SPC requirements of the Pennsylvania Code.

If your project will disturb more than one acre, please contact the Luzerne Conservation District office. The Conservation District reserves the right to determine whether or not this guide is acceptable for any particular project, on a case by case basis.

# TABLE OF CONTENTS

	Page
<b>E&amp;SPC Plan Narrative .....</b>	<b>4</b>
<b>Description of Erosion and Sediment Pollution Control Measures.....</b>	<b>6</b>
<b>Suggested Seeding Mixes and Rates .....</b>	<b>8</b>
<b>The Staging of Earthmoving Activities.....</b>	<b>12</b>
<b>Erosion and Sediment Pollution Control Plan Drawing .....</b>	<b>13</b>
<b>Luzerne Conservation District E&amp;SPC Plan Application .....</b>	<b>16</b>

# E&SPC PLAN NARRATIVE

## 1. GENERAL INFORMATION

A. Project Owner \_\_\_\_\_

Owner's Address \_\_\_\_\_

Owner's Phone \_\_\_\_\_

B. Project Name \_\_\_\_\_

Project Address \_\_\_\_\_

Municipality \_\_\_\_\_

Has the municipality been contacted concerning this project? \_\_\_\_\_  
(Check on local requirements and zoning)

Total Site Area \_\_\_\_\_ (Acres/Sq. Ft.)

Total Area to be Disturbed \_\_\_\_\_ (Acres/Sq. Ft.)

Description of Project \_\_\_\_\_

\_\_\_\_\_

C. Person(s) responsible for construction and maintenance of erosion and sediment pollution controls during earth disturbance activities:

Name \_\_\_\_\_

Address \_\_\_\_\_

Phone \_\_\_\_\_

D. For new home construction within a large development, you should locate a copy of the approved Erosion and Sediment Pollution Control Plan for that subdivision.

Name of Development \_\_\_\_\_

## E&SPC PLAN NARRATIVE (continued)

### 2. STORMWATER RUNOFF AND DRAINAGE

A. Name of Nearest Watercourse \_\_\_\_\_  
(i.e. Tobys Creek, wetland, roadside swale)

The Chapter 93 classification of streams or other water bodies \_\_\_\_\_  
(i.e. CWF, HQ-CWF, etc.- refer to the separate reference document)

Approximate Distance to Nearest Watercourse \_\_\_\_\_

**Note:** Earth disturbance within 50 feet of a stream or a water obstruction or encroachment within a water of the Commonwealth may require a DEP Chapter 105 Permit

Wetlands (check one):  Do not exist  Have been delineated  Not sure  
(refer to the separate reference document)

B. Are there any soils within the proposed area to be disturbed that end with the capital letters C, D

or F? (i.e. BkD) \_\_\_\_\_

(Luzerne County Soil Survey is required to complete this question, visit <http://soilmap.psu.edu/> and see separate reference document or contact the Conservation District office for a hard copy of the survey.)

**Note:** If you indicated “yes” to Question B above, the Small Project Plan may not be applicable, due to slope limitation exceedance.

C. Prior to the start of the project, does offsite or upslope drainage exist? \_\_\_\_\_  
(i.e. existing discharge pipes, drainage swales)

Will runoff from above the project site present problems or need to be controlled during construction? \_\_\_\_\_

D. Will the completion of your project increase storm water runoff volume or channelize storm water runoff? \_\_\_\_\_

**Note:** If you indicated “yes” to Questions C or D above, this runoff must be addressed in your E&SPC Plan.

# DESCRIPTION OF EROSION AND SEDIMENT POLLUTION CONTROL MEASURES

The following standard BMP drawings (Sections A-F) have been provided to fulfill the requirements of this plan. If you plan to use any of these recommended BMPs, please check the appropriate boxes for each Section and show the location of the sketch plan. If you plan to use alternative BMPs, you must provide drawings showing the details and specifications.

## A. Filter Fabric Fence

Filter fabric fence must be installed on existing contour below all disturbed area. Both ends of each fence section must be extended upslope at 45 degrees to the main fence alignment to in order to pond, trap and filter the sediment laden runoff. Should not be installed in streams, ditches or other areas of concentrated flow.

Will this BMP be used? Yes  No

### STANDARD CONSTRUCTION DETAIL #19 Standard Filter Fabric Fence (18" High)

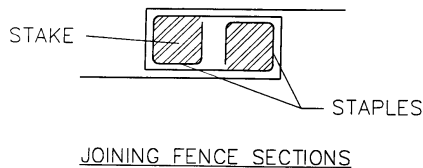

\*Stakes spaced @ 8' maximum. Use 2"x 2" wood or equivalent steel stakes.

Filter Fabric Fence must be placed at level existing grade. Both ends of the barrier must be extended at least 8 feet up slope at 45 degrees to the main barrier alignment.

Sediment must be removed when accumulations reach 1/2 the above ground height of the fence.

Any section of Filter fabric fence which has been undermined or topped must be immediately replaced with a Rock Filter Outlet. See Standard Construction Detail # 18.

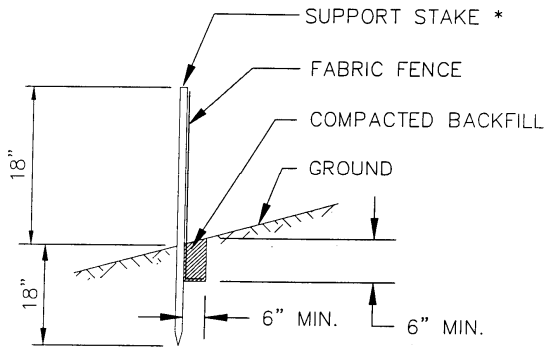

### STANDARD CONSTRUCTION DETAIL #18 Rock Filter Outlets

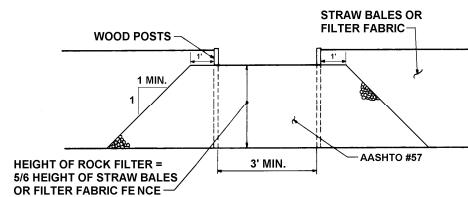
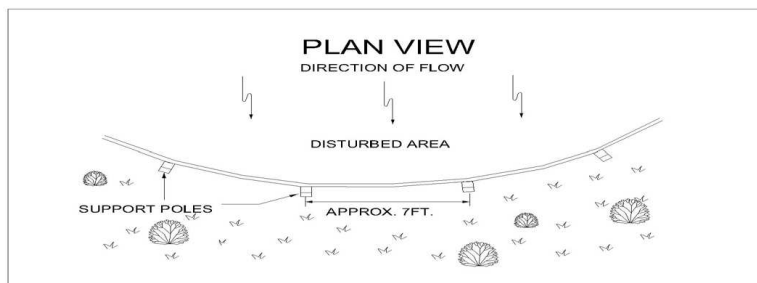
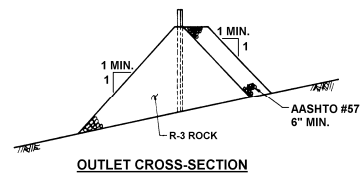

#### UP-SLOPE FACE

Sediment must be removed when accumulations reach 1/3 the height of the outlet.

**B. Straw Bale Barrier**

Straw bale barriers shall be placed on contour below all disturbed areas. Both ends of each fence section must be extended upslope at 45 degrees to the main fence alignment to in order to pond, trap and filter the sediment laden runoff. Straw bales deteriorate and should be replaced every 304 months. Should not be installed in streams, ditches or other areas of concentrated flow.

Will this BMP be used? Yes\_\_\_ No\_\_\_

**STANDARD CONSTRUCTION DETAIL #17  
Straw Bale Barriers**

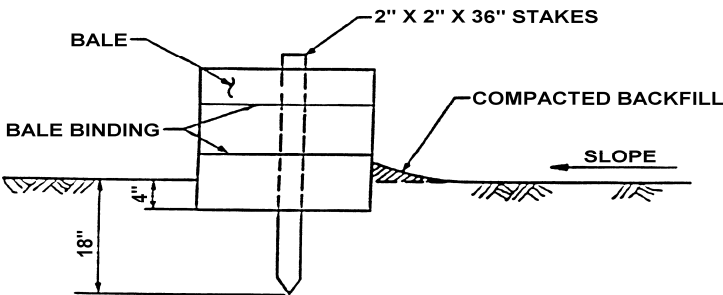

Straw Bale Barriers should not be used for more than 3 months.

Straw Bale Barriers shall be placed at existing level grade. Both ends of the barrier shall be extended at least 8 feet up slope at 45 degrees to the main barrier alignment.

Sediment shall be removed when accumulations reach 1/3 the above ground height of the barrier.

Any section of Straw Bale Barrier which has been undermined or topped shall be immediately replaced with a Rock Filter Outlet. See Standard Construction Detail #18.

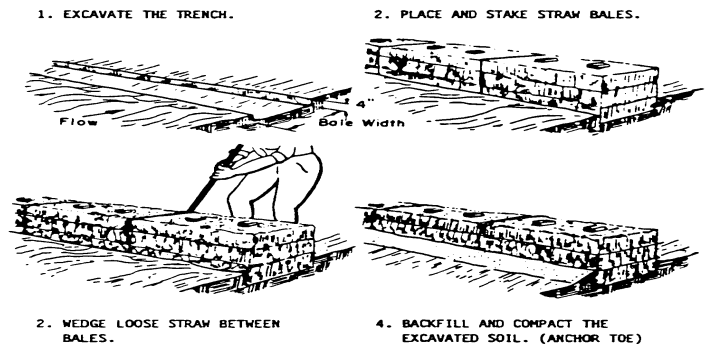
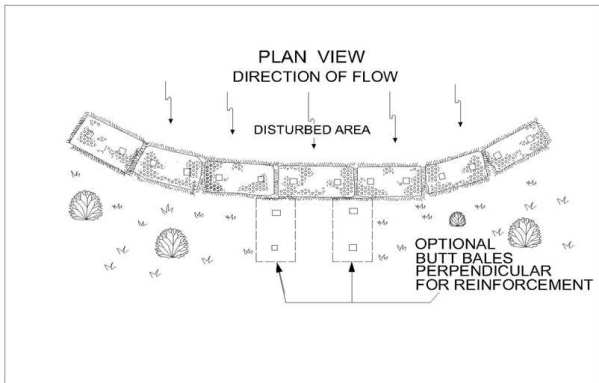

**C. Stabilized Rock Construction Entrance**

The purpose of this is to remove mud from tires and keep it from being tracked onto public roadway. Construction entrance thickness shall be constantly maintained to the specified dimensions by adding rock.

Will this BMP be used? Yes \_\_\_ No \_\_\_

**STANDARD CONSTRUCTION DETAIL #16  
Rock Construction Entrance**

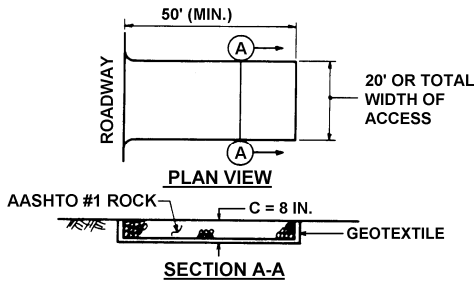

**MAINTENANCE:** Rock Construction Entrance thickness shall be constantly maintained to the specified dimensions by adding rock. A stockpile shall be maintained on site for this purpose. At the end of each construction day, all sediment deposited on paved roadways shall be removed and returned to the construction site.

**D. Disturbed Area Stabilization (check as appropriate)**

Prior to the completion of the project, state law requires that the project site be permanently stabilized with a uniform 70% perennial vegetative cover or other permanent non-vegetative cover with a density sufficient to resist accelerated surface erosion and subsurface characteristics sufficient to resist sliding and other movement. In other words, the soil cannot be left exposed. Descriptions of revegetation should include the seeding mixture to be used, top soil application, lime, fertilizer and mulch application rates.

- Permanent vegetation will be established per the recommendation of this guide.
- Alternative specifications have been developed for revegetation and are attached.

**Suggested Seeding Mixes and Rates  
Temporary And Permanent Stabilization Specifications**

**SPECIFICATIONS:** The Department recommends the use of the Penn State publication “Erosion Control & Conservation Plantings on Noncropland” as the standard to use for the selection of species, seed specifications, mixtures, liming and fertilizing, time of seeding, and seeding methods. Specifications for these items may also be obtained from Penn DOT’s Publication # 408, Section 804 or by contacting the applicable county conservation district. Upon selection of a reference, that reference must be used to provide all specifications for seeding, mulching, and soil amendments. The following specification will be used for this project:

(TEMPORARY) SPECIES: \_\_\_\_\_  
% PURE LIVE SEED: \_\_\_\_\_ %  
APPLICATION RATE: \_\_\_\_\_ LB./ACRE  
FERTILIZER TYPE: \_\_\_\_\_ (X-X-X)  
FERTILIZER APPL. RATE: \_\_\_\_\_ LB./ACRE  
LIMING RATE: \_\_\_\_\_ T./ACRE  
MULCH TYPE: \_\_\_\_\_  
MULCHING RATE: \_\_\_\_\_ T./ACRE

(PERMANENT) SPECIES: \_\_\_\_\_  
% PURE LIVE SEED: \_\_\_\_\_ %  
APPLICATION RATE: \_\_\_\_\_ LB./ACRE  
FERTILIZER TYPE: \_\_\_\_\_ (X-X-X)  
FERTILIZER APPL. RATE: \_\_\_\_\_ LB./ACRE  
LIMING RATE: \_\_\_\_\_ T./ACRE  
MULCH TYPE: \_\_\_\_\_  
MULCHING RATE: \_\_\_\_\_ T./ACRE  
ANCHOR MATERIAL: \_\_\_\_\_  
ANCHORING METHOD: \_\_\_\_\_  
RATE OF ANCHOR MATERIAL APPL.: \_\_\_\_\_ LB./ACRE  
SEEDING SEASON DATES: \_\_\_\_\_

(PERMANENT – STEEP SLOPE)  
SPECIES: \_\_\_\_\_  
% PURE LIVE SEED: \_\_\_\_\_ %  
APPLICATION RATE: \_\_\_\_\_ LB./ACRE  
FERTILIZER TYPE: \_\_\_\_\_ (X-X-X)  
FERTILIZER APPL. RATE: \_\_\_\_\_ LB./ACRE  
LIMING RATE: \_\_\_\_\_ T./ACRE  
MULCH TYPE: \_\_\_\_\_  
MULCHING RATE: \_\_\_\_\_ T./ACRE  
ANCHOR MATERIAL: \_\_\_\_\_  
ANCHORING METHOD: \_\_\_\_\_  
RATE OF ANCHOR MATERIAL APPL.: \_\_\_\_\_ LB./ACRE  
SEEDING SEASON DATES: \_\_\_\_\_

\*If more than one species is used, indicate application rate for each species.  
Note: Show information from this sheet on plan drawing.

**TABLE 15**  
**Plant Tolerances of Soil Limitation Factors**

Species	Growth Habit <sup>1</sup>	Tolerates				Minimum Seed Specifications <sup>3</sup>				
		Wet Soil	Dry Site	Low Fertility	Acid Soil (pH 5-5.5) <sup>2</sup>	Purity (%)	Ready Germ (%)	Hard Seed (%)	Total Germ (%)	Seeds/lb (1,000s)
<b>Warm-Season Grasses</b>										
Deertongue	bunch	yes	yes	yes	yes	95	75		75	250
Weeping lovegrass	bunch	no	yes	yes	yes	97	75		75	1,500
Switchgrass <sup>4</sup>	bunch	yes	yes	yes	yes	(60 PLS)			390	
Big bluestem	bunch	no	yes	yes	yes	(60 PLS)			150	
<b>Cool-Season Grasses</b>										
Tall Fescue	bunch	yes	no	yes	no	95	80		80	227
Redtop	sod	yes	yes	yes	yes	92	80		80	5,000
Fine fescues	sod	no	no	yes	no	95	80		80	400
Perennial ryegrass	bunch	yes	no	no	no	95	85		85	227
Annual ryegrass	bunch	yes	no	yes	no	95	85		85	227
Kentucky bluegrass	sod	no	no	no	no	85	75		75	2,200
Reed canarygrass	sod	yes	yes	yes	no	95	70		70	520
Orchardgrass	bunch	yes	yes	yes	yes	95	80		80	654
Timothy	bunch	yes	no	yes	yes	95	80		80	1,230
Smooth brome	sod	no	yes	yes	no	95	80		80	136
<b>Legumes<sup>5</sup></b>										
Crownvetch	sod	no	yes	yes	no	98	40	30	65	120
Birdsfoot trefoil <sup>6</sup>	bunch	yes	no	yes	yes	98	60	20	80	400
Flatpea	sod	no	no	yes	yes	98	55	20	75	10
Serecia lespedeza	bunch	no	yes	yes	yes	98	60	20	80	335
<b>Cereals</b>										
Winter wheat	bunch	no	no	no	no	98	85		85	15
Winter rye	bunch	no	no	yes	yes	98	85		85	18
Spring oats	bunch	no	no	no	no	98	85		85	13
Sundangrass	bunch	no	yes	no	no	98	85		85	55
Japanese millet	bunch	yes	no	yes	yes	98	80		80	155

<sup>1</sup> Growth habit refers to the ability of the species to either form a dense sod by vegetative means (stolons, rhizomes, or roots) or remain in a bunch or single plant form. If seeded heavily enough, even bunch formers can produce a very dense stand. This is sometimes called a sod, but not in the sense of a sod formed by vegetative means.

<sup>2</sup> Once established, plants may grow at a somewhat lower pH, but cover generally is only adequate at pH 6.0 or above.

<sup>3</sup> *Minimum seedlots are truly minimum, and seedlots to be used for revegetation purposes should equal or exceed these standards.* Thus, deertongue grass should germinate 75% or better. Crownvetch should have at least 40% readily germinable seed and 30% hard seed. Commonly, seedlots are available that equal or exceed minimum specifications. Remember that disturbed sites are adverse for plant establishment. Ready germination refers to seed that germinates during the period of the germination test and that would be expected, if conditions are favorable, to germinate rapidly when planted. The opposite of ready germination is dormant seed, of which hard seed is one type.

<sup>4</sup> Switchgrass seed is sold only on the basis of pure live seed (PLS).

<sup>5</sup> Need specific legume inoculant. Inoculant suitable for garden peas and sweetpeas usually is satisfactory for flatpea.

<sup>6</sup> Birdsfoot trefoil is adapted over the entire state, except in the extreme southeast where crown and root rots may injure stands.

**TABLE 16**  
**Mulch Application Rates**

Mulch Type	Application Rate (Min.)			Notes
	Per Acre	Per 1,000 sq. ft.	Per 1,000 sq. yd.	
Straw	3 tons	140 lb.	1,240 lb.	Either wheat or oat straw, free of weeds, not chopped or finely broken
Hay	3 tons	140 lb.	1,240 lb.	Timothy, mixed clover and timothy or other native forage grasses
Wood Cellulose	1,500 lb.	35 lb.	310 lb.	Do not use alone in winter, during hot and dry weather or on steep slopes ( $\geq$ 3:1)
Wood	1,000 lb. Cellulose	25 lb.	210 lb.	When used over straw or hay
Wood Chips	4 - 6 tons	185 - 275 lb.	1,650 - 2,500 lb.	May prevent germination of grasses and legumes

**MULCHING** - Mulches absorb rainfall impact, increase the rate of infiltration, reduce soil moisture loss due to evaporation, moderate soil temperatures, provide a suitable environment for germination, and protect the seedling from intense sunlight. All seeded areas should be mulched to minimize the potential for failure to establish an adequate vegetative cover. Mulching may also be used as a temporary stabilization of disturbed areas in non-germinating seasons.

**FIGURE 19**  
**Straw Mulch At Various Rates Of Application**

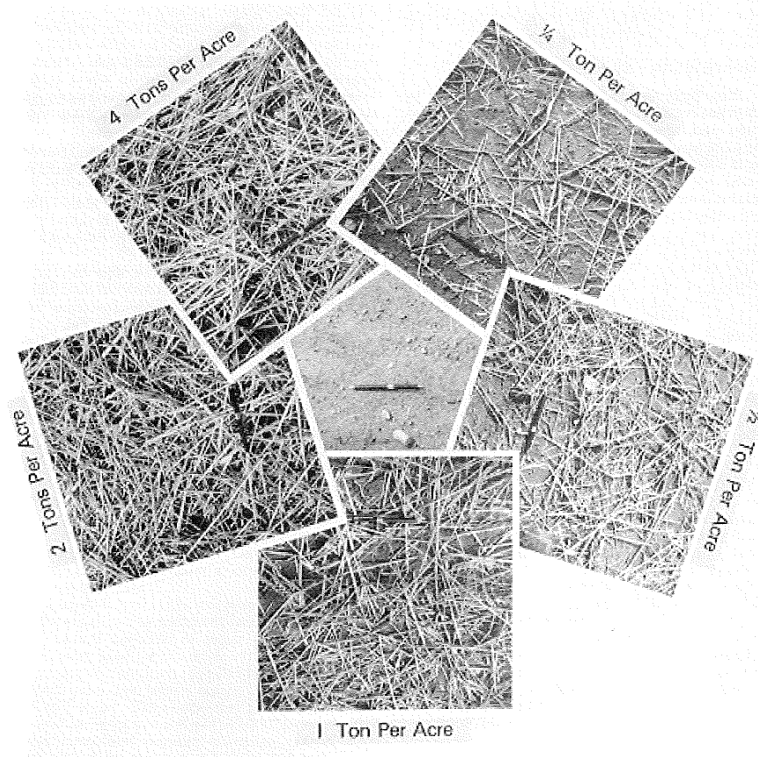

Apply mulches at the rates shown in **Table 16**

Straw and hay mulch should be anchored immediately after application to prevent being windblown. A tractor-drawn implement may be used to "crimp" the straw or hay into the soil. This method is limited to slopes no steeper than 3:1. The machinery should be operated on the contour. (Note: Crimping of hay or straw by running over it with tracked machinery is not recommended.)

Asphalt, either emulsified or cut-back, containing no solvents or other diluting agents toxic to plant or animal life, uniformly applied at the rate of 31 gallons per 1000 sq. yd. may be used to tack mulch.

**E. Construction Sequence** (List steps, numbering)  
(See this page for example)



Is this BMP provided? Yes \_\_\_ No \_\_\_

A construction sequence is a step by step description of a proposed earthmoving activity relating the various stages of construction to the BMPs that must be installed prior to each stage. It should also describe the conditions of stabilization that will exist prior to removal of temporary BMPs or the conversion to permanent stormwater management facilities as well as the process of converting those facilities.

---

---

---

---

---

---

---

---

**Example**

**THE STAGING OF EARTHMOVING ACTIVITIES**

ALL EARTH DISTURBANCE ACTIVITIES SHALL PROCEED IN ACCORDANCE WITH THE FOLLOWING SEQUENCE. EACH STAGE SHALL BE COMPLETED BEFORE ANY FOLLOWING STAGE IS INITIATED. CLEARING AND GRUBBING SHALL BE LIMITED ONLY TO THOSE AREAS DESCRIBED IN EACH STAGE.

1. At least 7 days before starting any earth disturbance activities, the operator shall invite all contractors involved in those activities, the landowner, all appropriate municipal officials, the erosion and sediment control plan preparer, and the Conservation District to an on-site meeting. Also, at least 3 days before starting any earth disturbance activities, all contractors involved in those activities shall notify the Pennsylvania One Call System Incorporated at 1-800-242-1776 for buried utilities locations.
2. INSTALL Rock Construction Entrance (RCE) and Silt Fence 1 and 2 (SF1 & SF2).
3. After Stages 1 and 2 have been completed and stabilized, CONSTRUCT AND STABILIZE the lot improvements.
4. After Stage 3 has been completed and all areas have achieved final stabilization, REMOVE silt fence, straw bales, etc. and all accumulated sediment. IMMEDIATELY STABILIZE THE AFFECTED AREAS.  
An area shall be considered to have achieved final stabilization when it has a minimum uniform 70% perennial vegetative cover or other permanent non-vegetative cover with a density sufficient to resist accelerated surface erosion and subsurface characteristics sufficient to resist sliding and other movement.

**F. Erosion and Sediment Pollution Control Plan Drawing:**  
(See page 14 & 15 for example)



Is this BMP provided? Yes\_\_\_\_ No\_\_\_\_

**Erosion & Sediment Pollution Control Plan**

**North Arrow:**

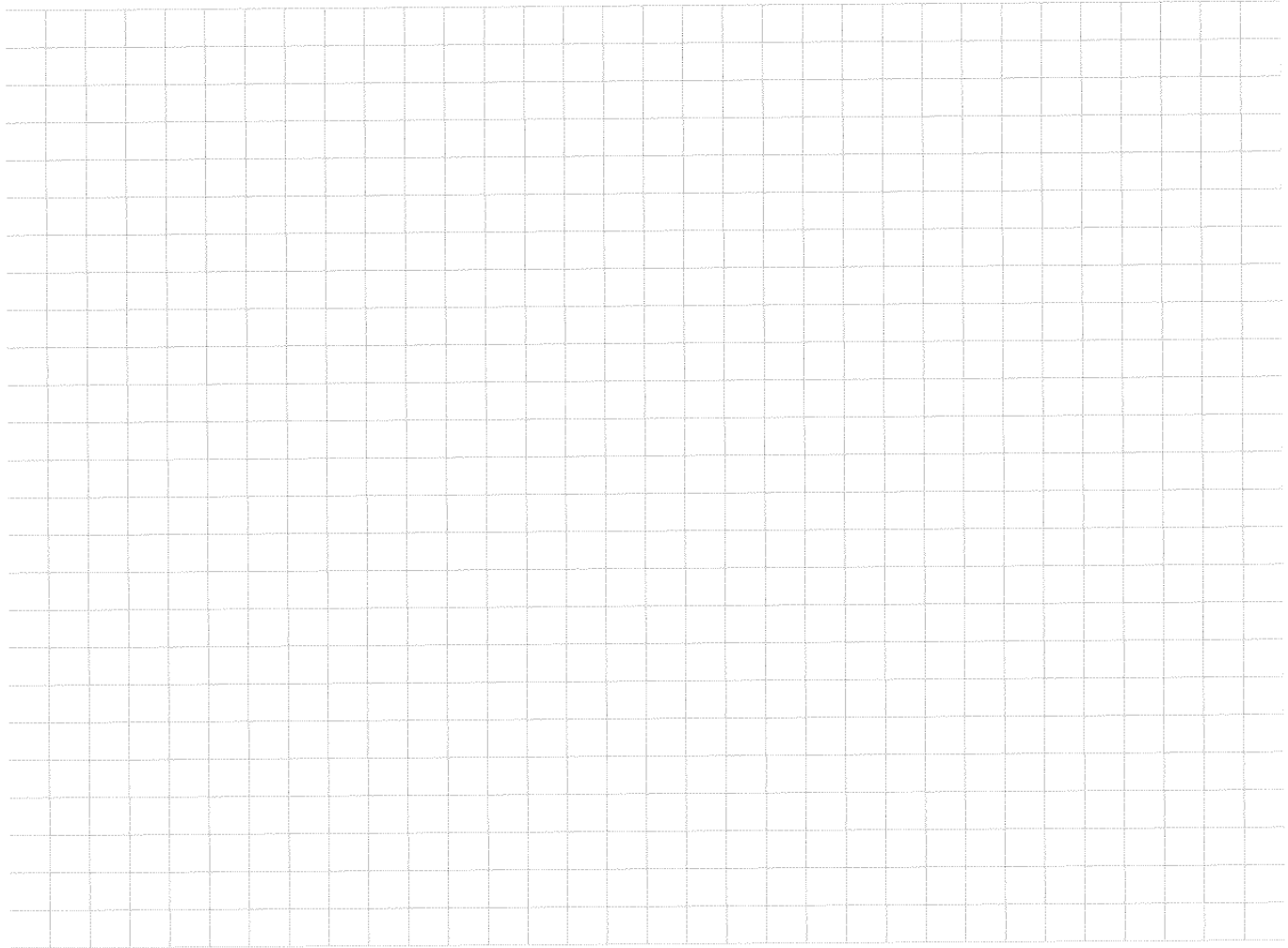

**Map Legend**



# E+S PLAN

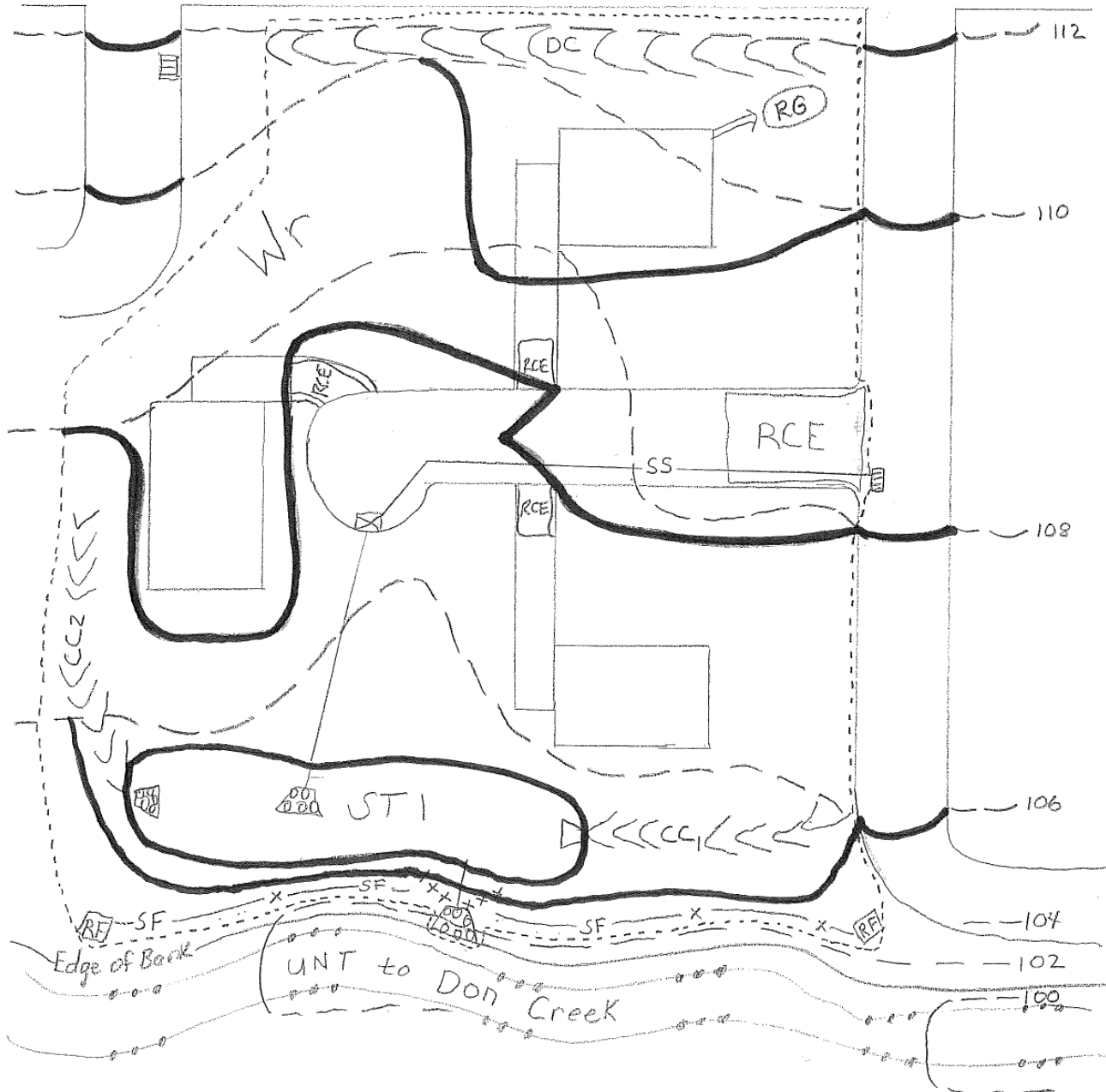

## LEGEND

- RCE
- SILT FENCE
- ROCK FILTER
- OUTLET PROTECTION

- LIMITS OF CONSTRUCTION
- DIVERSION CHANNEL
- COLLECTOR CHANNEL
- STORM SEWER

- EXISTING CONTOUR
- PROPOSED CONTOUR
- SOIL TYPE

- RAIN GARDEN
- ROOF DRAIN
- 1" = 50'



SITE ID #  
XX16XX

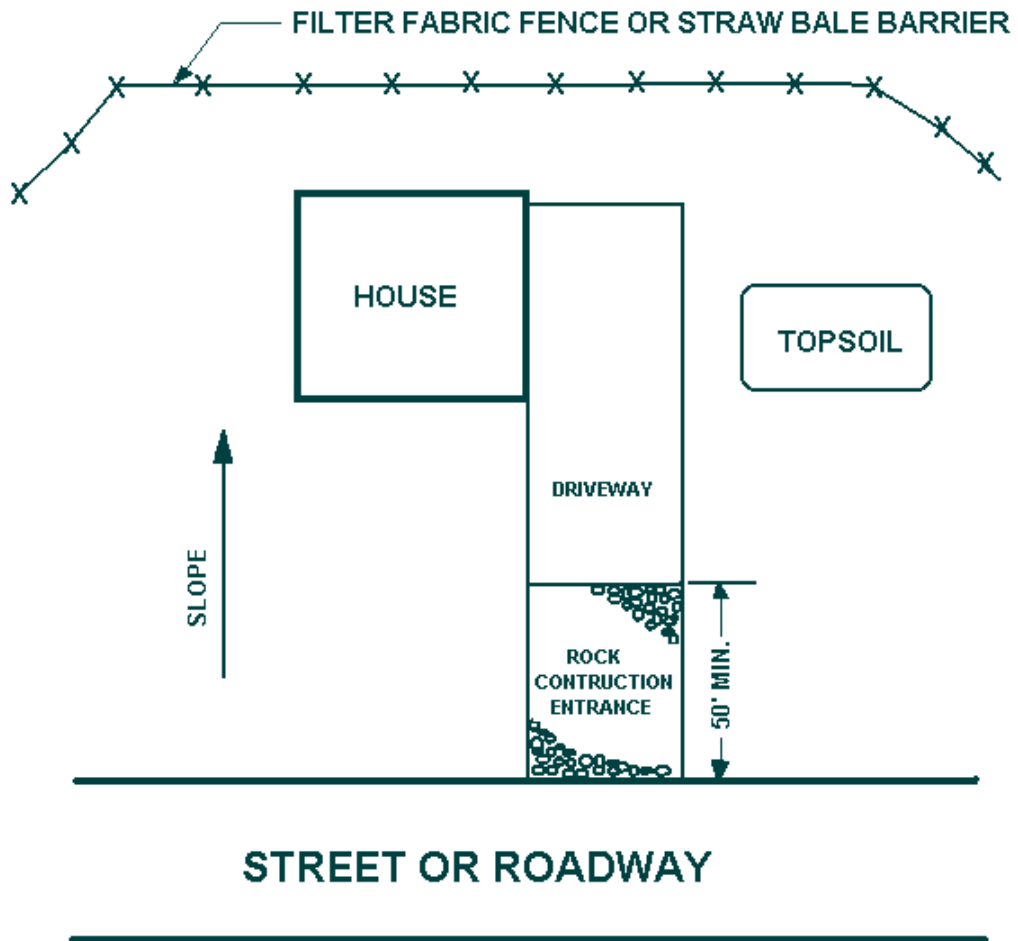



# LUZERNE CONSERVATION DISTRICT

325 Smiths Pond Road  
Shavertown, PA 18708  
Phone: (570) 674-7991  
Fax: (570) 674-7989  
www.luzernecd.org

## EROSION & SEDIMENT POLLUTION CONTROL (E&SPC) PLAN REVIEW APPLICATION

Project Name: \_\_\_\_\_

Project Owner: \_\_\_\_\_

Project Address/Location: \_\_\_\_\_

Owner's Address: \_\_\_\_\_

\_\_\_\_\_

\_\_\_\_\_

\_\_\_\_\_

\_\_\_\_\_

Municipality: \_\_\_\_\_

Owner's Phone: \_\_\_\_\_

Total Project Acres: \_\_\_\_\_

Number of Residential of Lots/Units: \_\_\_\_\_

Total Acres to be Disturbed: \_\_\_\_\_

Plan Preparer: \_\_\_\_\_

Site Supervisor: \_\_\_\_\_

Preparer's Phone: \_\_\_\_\_

Site Phone: \_\_\_\_\_

Preparer's Fax: \_\_\_\_\_

Preparer's Email: \_\_\_\_\_

Fee Amount: \_\_\_\_\_

NPDES Permit Fee Amount\*\*: \_\_\_\_\_

**(See worksheet on Page 2)**

**\*\* If applying for an NPDES Permit, the following additional fees apply:  
\$500 for General Permits or \$1,500 for Individual Permits payable by separate check to "Luzerne County Clean Water Fund".  
\$100 per disturbed acre payable by another separate check to "Commonwealth of Pennsylvania Clean Water Fund".**

**A Revision Fee equal to 40% of the initial E&SPC Plan Review Fee will apply to the second and subsequent technical comment/deficiency/review letters.**

**If any deficiencies regarding this submission are not addressed within 90 days of notice from this office, a new submission and fee will be required before any plan approval and construction can occur.**

### For District Use Only

Initial Date Received: \_\_\_\_\_

Date of Final Approval: \_\_\_\_\_

Plan Reviewer's Signature: \_\_\_\_\_

The applicant hereby acknowledges that the E&SPC Plan is reviewed for adequacy to control erosion and sedimentation, in accordance with 25 Pa. Code Chapter 102 and the Clean Streams Law, and not for adequacy of structural design.

The applicant shall retain full responsibility for any damage which may result from any construction activity notwithstanding Conservation District approval of the subject E&SPC Plan.

It is understood that approval of the plan submitted with this application shall be valid only for the duration of the initial project granted by the municipality.

All municipal renewals of this project will require resubmission and approval by the Conservation District.

In no case shall this approval extend beyond two (2) years.

**The applicant hereby agrees as follows:**

1. To notify the Luzerne Conservation District in writing or by phone at least 72 hours prior to any earth disturbance activity.
2. To notify the Luzerne Conservation District upon completing the project.
3. To maintain a copy of the approved E&SPC Plan on the project site.
4. To allow Luzerne Conservation District representatives to enter the project site for inspection.
5. That any conveyance of the project prior to its completion will include the transfer to the subsequent owner(s) the full responsibility of compliance with the approved E&SPC Plan and applicable regulations.

**Applicant's Name (please print):** \_\_\_\_\_

**Applicant's Signature:** \_\_\_\_\_ **Date:** \_\_\_\_\_

**REVIEW FEE WORKSHEET**

(As per the current Luzerne Conservation District Fee Schedule dated July 20, 2009)

<b>Administrative Fee</b>	Only for E&SPC Plans not associated with NPDES Permits = \$100	\$
<b>Residential</b>	Fee based on number of lots/units. See current Fee Schedule for applicable amount.	\$
<b>Industrial/Commercial</b>	Fee based on the disturbed area or linear feet for utility lines. See current Fee Schedule for applicable amount.	\$
<b>Small Projects</b>	All small project reviews = \$100 See current Fee Schedule for types of projects.	\$
<b>Non-Profit, Open Space, Greenways &amp; Outdoor Recreation</b>	\$500 (basic fee) + _____ (\$20 per disturbed acre)	\$
	<b>TOTAL REVIEW FEE:</b> (Check made payable to the Luzerne Conservation District)	\$
<b>NPDES Base Permit Fee (If applicable)</b>	General NPDES Permits = \$500 Individual NPDES Permits = \$1,500 (Separate check made payable to the Luzerne County Clean Water Fund)	\$
<b>NPDES Acreage Permit Fee (If applicable)</b>	General & Individual NPDES Permits = \$100 per disturbed acre For fractional acreage, the acreage shall be rounded to the closest whole number. (Separate check made payable to the Commonwealth of PA Clean Water Fund)	\$